

C4E400V
C4E450V
C4E500V



The Cargo C4E400V-500V for heavy duty is a range of electric trucks with ergonomic solutions, advanced technology and top level performance. They are designed for demanding lifting duties in heavy applications. Lifting capacity from 4000kg up to 5000kg, lift heights up to 6120mm.



Technical Details	C4E400V	C4E450V	C4E500V
Power unit	electrical	electrical	electrical
Operating type	driver seated	driver seated	driver seated
Rated capacity	kg 4000	4500	4900
Load centre	mm 500	500	500
Load per axle without load, front/rear	kg 3500/3300	3490/3630	3800/3870
Load per axle with load, front/rear	kg 9600/1200	10490/1130	11570/1100
Number of wheels, front/rear	2-4/2	2-4/2	2-4/2
Wheel type, front—rear ¹⁾	C/SE/PN/SE.TW/ PN.TW	C/SE/SE.TW/PN.TW	C/SE/SE.TW/PN.TW
dimension, front	28x10x22/250-15/ 250-15/7.00-15/7.00-15	28x12x22/250-15 ⁷⁾ /7.00-15/7.00-15	28x12x22/28x12.5-15/ 7.00-15/7.00-15
dimension, rear	22x8x16/23x9-10/ 23x9-10	22x8x16/23x9-10	22x8x16/23x9-10
Centre of wheels, front	mm 1164/1132/1132/1330/ 1330	1215/1132/1330/1330	1215/1202/1330/1330
Centre of wheels, rear	mm 1154/1154/1154	1154/1154	1154/1154
Fork arm carriage acc. to ISO-FEM	III A	III A	III A
Travel speed, without/with rated load	km/h 17/15 ²⁾	17/15 ²⁾	17/14 ²⁾
Service brake	hydraulic	hydraulic	hydraulic
Parking brake	hand brake	hand brake	hand brake
Lift speed, without/with rated load	m/s 0.47/0.27	0.47/0.26	0.44/0.23
Lowering speed, without/with rated load	m/s < 0.6	< 0.6	< 0.6
Nom. draw-bar pull, without/with load	N 5338/5238	5338/5188	5338/5188
Max. draw-bar pull, without/with load (S2 5')	N 15130/14460	15130/14330	15130/14300
Gradient, without/with rated load (S2 30')	% 11/7	10/6	9/5
Max. gradient, without/with rated load (S2 5')	% 23/13	22/12	21/11
Drive motor	kW 17	17	17
Lift motor	kW 18	18	18
Battery capacity	V/Ah 80/625—775	80/625—775	80/625—775
Battery weight	kg 1872	1872	1872
Weight with battery	kg 6800	7120	7670
Steering system	hydraulic	hydraulic	hydraulic
Speed control	electronical	electronical	electronical

Dimensions, mm	C4E400V	C4E450V	C4E500V
x Front axle to fork face	509 ³⁾	509 ³⁾	529 ⁴⁾
y Wheel base	1810	1810	1810
α/β Mast tilt forward/backward	2°30'/10	2°30'/10	2°30'/10
h ₆ Height overhead guard	2450	2450	2450
h ₇ Height of driver's seat	1294	1294	1294
l ₂ Truck length incl. back of fork	2750 ³⁾	2750 ³⁾	2770 ⁴⁾
b ₁ Chassis, width	1418/1360/1756 ⁵⁾	1520/1360/1756 ⁵⁾	1520/1520/1756 ⁵⁾
s Fork thickness	50	50	60
e Fork width	150	150	150
l Fork length	1000	1000	1000
m ₁ Floor clearance under mast	150	150	150
m ₂ Floor clearance mid wheelbase	160	160	160
A _{st} Aisle width, mm	4323/ Pallet size 800x1200/1000x1200 ⁶⁾	4323/ 4123 ³⁾	4343/ 4143 ⁴⁾
W _a Turning radius	2414	2414	2414

1) C = Cushion, SE = Superelastic, PN = Pneumatic, TW = Twin

2) Cushion wheels = max. speed 16km/h

3) With side shift = +32mm

4) With side shift = +39mm

5) C/SE-PN/SE.TW-PN.TW

6) Shortside handling / longside handling

7) On request SE 28x12.5-15 (b₁ = 1520mm)

Mast, mm	Duplex		Duplex FFL			Triplex			Triplex FFL			
h_3 Lift height	3150	3650	3150	3650	4150	4950	5550	6060	4300	4950	5550	6050
C4E400V, C4E450V												
h_1 Height of mast, min.	2400	2650	2400	2650	2900	2500	2700	2900	2285	2500	2700	2900
h_2 Free lift	100	100	1552	1802	2052	75	75	75	1442	1657	1857	2057
h_4 Height of mast, max.	3948	4448	3998	4498	4998	5750	6350	6892	5143	5793	6393	6893
C4E500V												
h_1 Height of mast, min.	2450	2700	2450	2700	3000	2550	2750	2950	2335	2550	2750	2950
h_2 Free lift	100	100	1552	1802	2052	75	75	75	1442	1657	1857	2057
h_4 Height of mast, max.	3991	4491	4048	4548	5048	5820	6420	6960	5193	5843	6443	6943

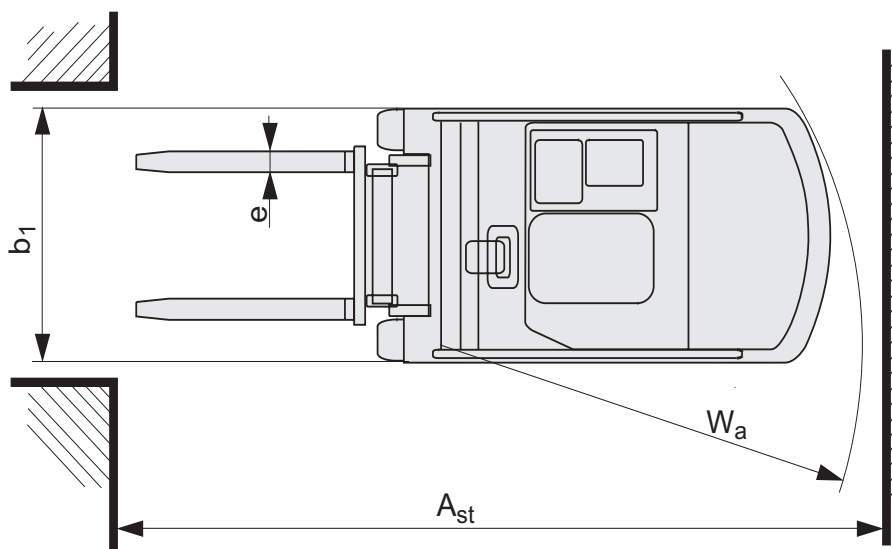
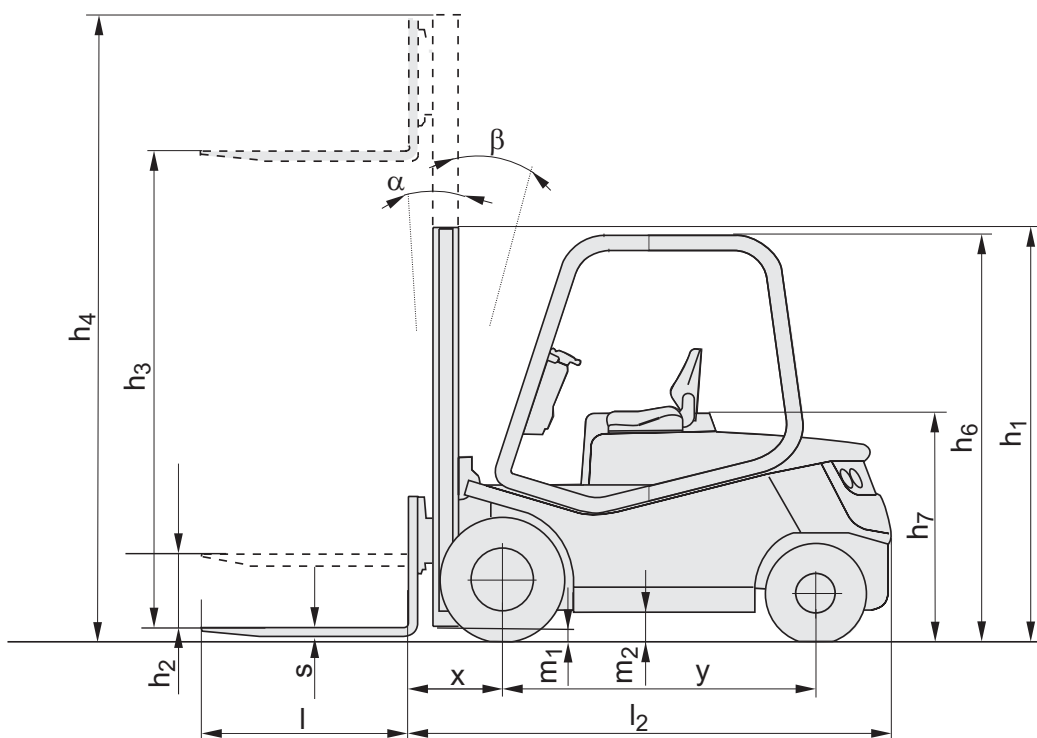

Truck performance and dimensions are nominal and subject to tolerances.
 BT Products AB products and specifications are subject to change without notice.
 All data is based on VDI 2198.



- High visibility and stability. The position of the uprights, which are widely spaced, guarantees excellent visibility and at the same time gives a rigid structure even at great height.
- Large front and rear wheels, which are available in a number of models, guarantee comfort, long life, greater adaptability to the road surface, and extremely easy handling of the truck.
- Various drive programs can be selected by simply pressing the push-buttons on the steering column. The operator can choose between 3 different drive programs, as well as an additional reduced speed setting.
- The overhead guard is fully suspended on silent block elements.
- AC power means exceptional performance levels, combined with reduced energy consumption and lower service and maintenance requirements.
- As well as guaranteeing constantly effective braking action, the use of oil bathbrakes allows savings on routine servicing costs.
- The CAN-Bus simplifies the electrical system by reducing wiring and increases the flexibility of the truck control system.

Truck features	C4E400V	C4E450V	C4E500V
Adjustable fork width	S	S	S
Tilting mast	S	S	S
Twin drive tyres	O	O	O
Controls and instruments			
Hydraulic steering	S	S	S
Sideshift	O	O	O
Information display	S	S	S
Electronic fingertip controls	O	O	O
Mini-joystick electronic controls	O	O	O
Driving features			
Electronic regenerative brakes	S	S	S
Three driving programs	S	S	S
Safety features			
Clear-view mast	S	S	S
Driver detection system	S	S	S
Emergency cut-off	S	S	S
Programmable performance	S	S	S
Drivers compartment features			
Adjustable steering wheel	S	S	S
Enclosed cab with or without heating	O	O	O
Maintenance features			
Easy access for maintenance	S	S	S
Fault diagnosis facility	S	S	S
Oil bath brakes	S	S	S
Battery management features			
Battery status indicator	S	S	S
Battery discharge prevention system	S	S	S
Special applications			
Coldstore version	O	O	O
EEx version (ATEX)	O	O	O

S = Standard feature

O = Optional feature

— = Not available