



Pedestrian Pallet Truck with platform — heavy duty

The ORION Range with modern styling is ideally suited for high performance applications regarding dock loading / cross-docking / transportation. LPE240 is an extremely fast, robust and strong truck. The chassis width is only 790mm for optimal handling in tight areas.

- The **comfortable steering arm**, with its modern design, facilitates one hand operation — either left or right hand. Can be equipped with power assisted steering. The display on the handle gives useful information.
- The **BT POWERDRIVE system**. The unique integration of contactless controls, CAN-Bus communication and a separately excited drivemotor gives many advantages. The contactless controls give smooth and effortless driving. The CAN-Bus communication provides quick, reliable transmission and only a few communication cables are needed. The separately excited drivemotor allows easy programming of its performance — top speed, acceleration and automatic speed reduction — to suit the application.
- Choice of having **PIN Code** (up to 100) instead of key. Provides access control. Each code can store individual parameters to meet the driver's skill / environment.
- **Regenerative braking**, energy back to the battery.
- **Integrated spring loaded, foldable platform** together with stable and comfortable gates provides safe high speed operation and maximum efficiency.
- The truck is equipped with **POWERTRAK** drive unit configuration — a BT patent. The drive wheel pressure is constantly adjusted due to the weight of the load. The result is excellent stability, optimal traction and steering force.
- High battery capacities — two different easy access battery compartments with **battery exchange** both upwards and sideways — for multishift operations.
- Totally greasable lift- and drive system.



Technical Details		LPE240
Rated capacity	kg	2400
Load centre	mm	600
Weight without battery	kg	685
Max. axle pressure drive wheel, without/with rated load	kg	510/835
Max. axle pressure castor wheel, without/with rated load	kg	150+150/295+295
Max. axle pressure fork wheels, without/with rated load	kg	105+105/1075+1075
Castor wheels, Vulkollan	mm	Ø 150x50
Fork wheels, Vulkollan	mm	Ø 85x75
Drive wheel, Vulkollan	mm	Ø 250x75, 250x105
Travel speed, without/with 1000kg/with rated load	km/h	12/12/8.5 ¹⁾
Lift speed fork, without/with rated load	m/s	0.06/0.04
Lowering speed fork, without/with rated load	m/s	0.04/0.04
Gradient, without/with rated load	%	15/8
Service-/parking brake		1 stage electromagnetic brake
Drive motor/Intermittent rating	kW/%	2.5/60
Lift motor/Intermittent rating	kW/%	2.2/10
Steering system		steering arm
Speed control, number of steps		stepless
Steering arc	°	180

1) With rated load, medium battery compartment: Travel speed = 8.0km/h

Dimensions, mm		LPE240
h ₂₃	Total lift height	210 ²⁾
x	Front axle to fork front face, fork raised/lowered	909/958 ²⁾
h ₂₃	Total lift height	225 ³⁾
x	Front axle to fork front face, fork raised/lowered	886/958 ³⁾
h ₇	Platform height	184
h ₁₄	Height of handle in neutral pos.	1450
h ₁₃	Height of lowered fork	85
b ₁	Chassis, width	790
e	Fork width	180
l	Fork length	800/950/1000/1150/1200/1450/1550/1950/ 2150/2350
b ₅	Width across fork, min./max.	450/520/536/550/685
l ₄	Platform length	422
m ₁	Floor clearance	55

2) Pallet handling

3) Roll cage handling

Data is based on small size battery compartment, l=1150mm

Dimensions — Battery compartment			Small	Medium
y	Wheel base, fork raised/lowered	mm	1605/1725	1691/1811
l ₂	Truck length incl. back of fork, platform up/down	mm	745/1167	831/1253
A _{st}	Aisle width, min., platform raised/lowered (Pallet 800x1200 mm)	mm	2265/2687	2351/2773
W _a	Turning radius, platform up/down	mm	1725/2147	1811/2233
	Battery capacity, min./max.	Ah	300/465	300/620
	Voltage	V	24	24
	Battery weight, min./max.	kg	250/380	280/500

Performance may vary due to motor and system efficiency tolerance and represents nominal values obtained under typical operating conditions.

BT Products AB products and specifications are subject to change without notice.

All datas are based on VDI 2198.

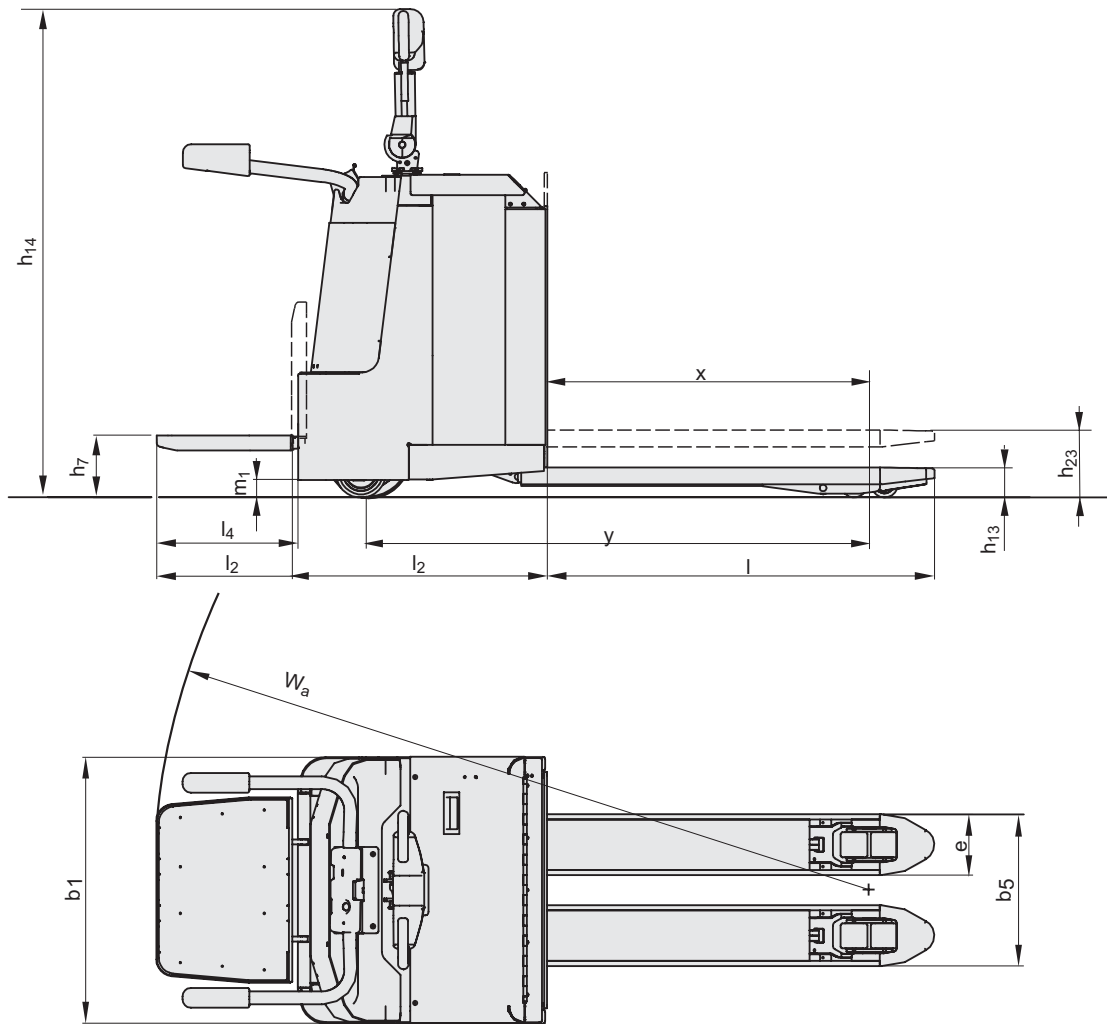

ORION Range

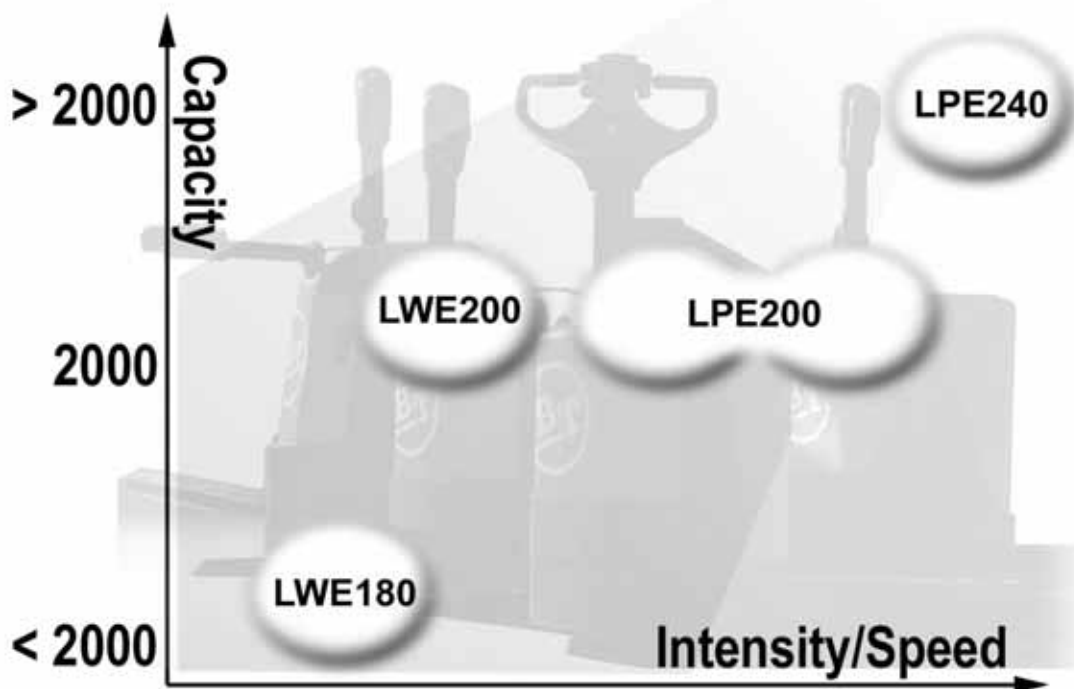



Options

- **Load support**
To provide additional safety for operator and load.
- **Fixed back rest**
The driver is well protected and has a cushion to lean against. For transportation over longer distances.
- **Fixed safety guards**
Large safety guards for increased driver security.
- **Climber skids**
Allow effective pallet entry/exit regardless of pallet type.
- **Cold store specification**
For operation in temperatures down to -35° C.
- **Battery change table**
For fast exchange of batteries toward the side.



BT
SE-595 81 Mjölby Sweden
Tel: +46 (0)142 860 00
Fax: +46 (0) 142 866 00
Email: info@bt-forklifts.com
www.bt-forklifts.com



Handling innovation